

**Your Partner in
Exhaust and Emission**

AFTERMARKET

EURO 6 SYSTEMS FROM TURBO TO TAILPIPE

going the extra mile



Dinex.net

Stepping up to the latest standard

Air pollution is a major concern to European communities and individuals, and exhaust gases must be controlled to reduce the negative impact.

The official constraints on vehicle emissions follow a natural path. The present Euro VI norm reduces the particulate and NOx emissions to unprecedented levels, promising to make heavy transport more friendly to the environment than ever before.

Euro VI and beyond

This important endeavour requires advanced exhaust and emission solutions. Dinex products meet or exceed the Euro VI norm, so truck manufacturers and the after-market naturally rely on us to help them equip for the new standard. In fact, we even deliver technologically advanced silencers for trucks, even though type approval is not yet required for these.

The greener, the better

Every day we work hard to reach even lower levels of particulate and NOx emissions, and we are every bit as ambitious with our aftermarket products as we are with our original equipment parts.

We are constantly working on new technologies, new products and more effective solutions that may be applied in current and future exhaust systems. We work hard to ensure emission compliance with OE equipment, but also to find ways to improve on areas like noise reduction, back-pressure performance and fuel consumption.

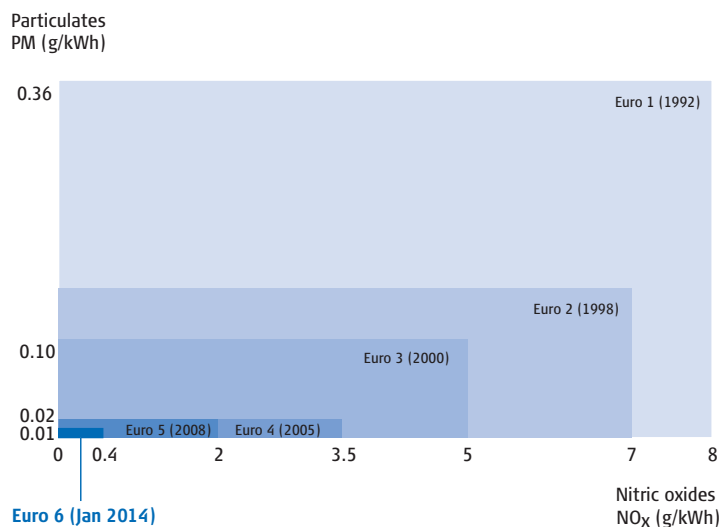

Cleaner air out of the exhaust pipe than the air you breathe!*

*In comparison to air polluted areas.





THE
GREENER
THE
BETTER

Table of content

2	Introduction to Dinex
7	DAF Euro 6 systems
8	IVECO Euro 6 system
9	MAN Euro 6 system
10	MERCEDES-BENZ Euro 6 system
11	RENAULT Euro 6 system
12	SCANIA Euro 6 system
13	VOLVO Euro 6 system
14	Scope of supply
16	Temperature Sensors
17	NOx Sensors
18	Dinex worldwide

We provide a complete

With more than 15,000 products available we offer the world's widest product range for on-road transport (LCV, trucks and buses), off-road and construction equipment.

- Catalysts
- Substrates
- Diesel particle filters
- Front pipes
- Tailpipes
- Pipe insulation
- Clamps
- Flex pipes and bellows
- Sensors
- Fittings

Integrated OE quality

Reliable performance is our main priority. We handle all production of ceramics, coating and metal forming in our own factories, and our entire programme is 95% in-house manufactured. This is our way to ensure optimum quality that equals and in many cases even surpasses original equipment.

Certified and approved

Probably needless to say, but Dinex is certified according to a number of international standards, including:

ISO 9001, ISO 14001, ISO 18001, ISO 50001,
IATF 16949



Euro 6 system product range

Flexible parts

Dinex uses 2S+, 3S flex pipes and bellow design to comply with leakage requirements.

Sensors

Sensors are designed to monitor exhaust system parameters and secure systems proper operation.

Emission technologies

DOC (Diesel Oxidation Catalyst), SCR (Selective Catalyst Reduction) catalysts and DPF's (Diesel Particle Filter) can be installed into our silencer systems.

Silencers

Lock sealed, stamped or welded units. We supply alu or stainless steel in different sizes in-house with our own tooling shop.

Clamps

The portfolio includes Flat clamps, DIN clamps, V-clamps, Flex clamps and U-clamps.

Pipes

Bending from 22 mm to 152,4 mm in alu or stainless steel.

Insulation Techniques

Mainly used in systems with emission regulations.

Tailpipes

Direct replacement parts as well as universal tailpipes. Excellent quality parts made from alu, stainless steel or polished stainless steel.

Exhaust fittings

All fittings are made inhouse for complete systems supply.

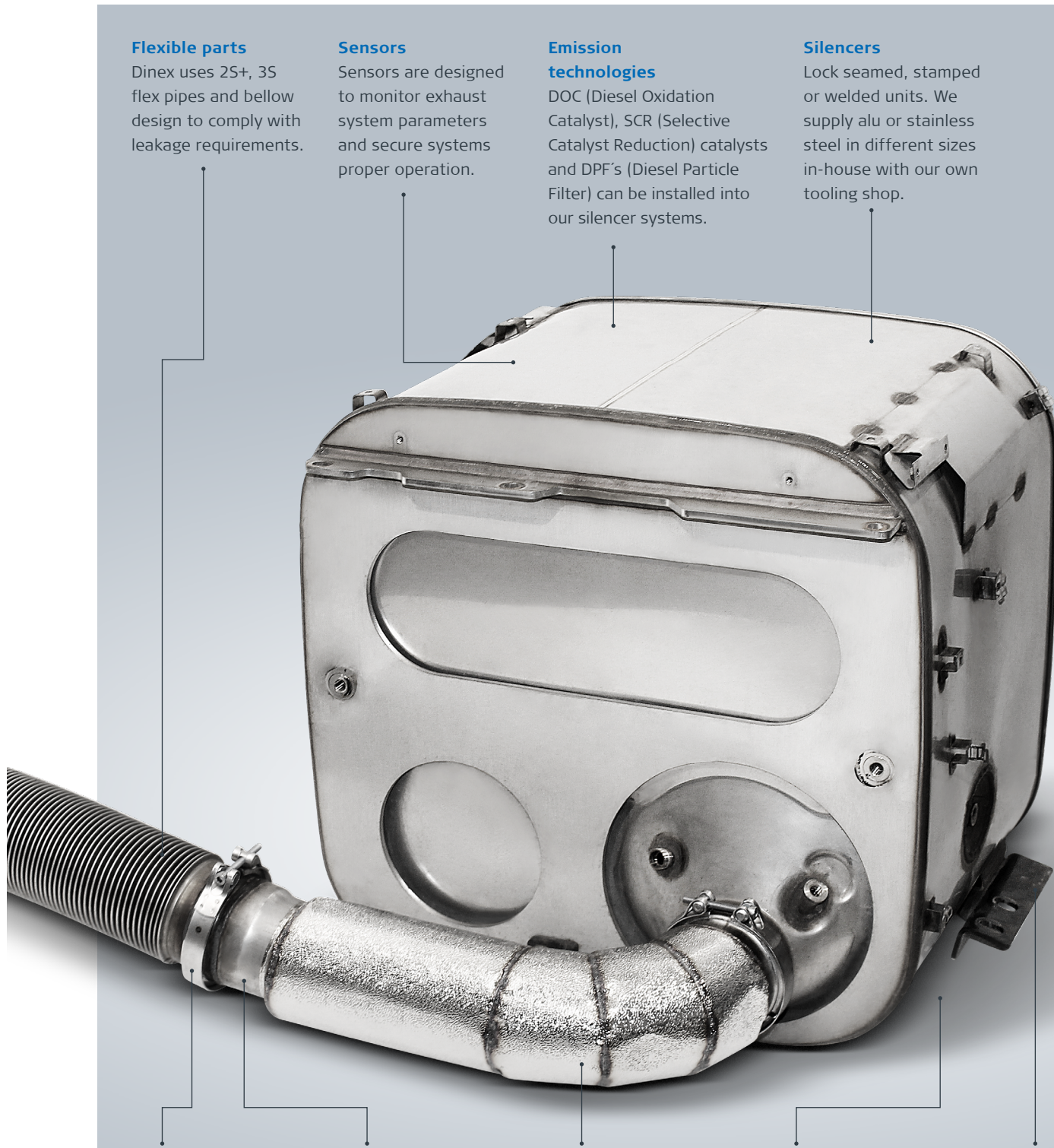

Widest product range from turbo to tailpipe

All models - all years

Global in-house manufacturing

Direct replacement of original exhaust parts

Next day delivery

Local presence - We speak your language

Local technical training sessions

ALL YOU NEED FROM TURBO TO TAILPIPE

going the extra mile

The logo for DINEX, featuring the word "DINEX" in a bold, blue, sans-serif font. The letters "I" and "N" are stylized with horizontal lines through them. Below the text are three horizontal blue lines of varying lengths, creating a sense of motion or a stylized underline.

XF

EURO 6 - Horizontal RHD / LHD

ATS solution comprising cordierite DPF with relatively high PGM loading for soot-free emissions and cordierite DOC and SCR for the highest catalytic efficiency. Coupled with Dinex bellow and insulation technologies, perfect for OE replacement. ATS silencer consists of two sections with DOC and DPF and the section with SCR. Dinex also offers all exhaust pipes and other parts related to exhaust systems for DAF trucks.

Coming in Q4-19

Replacement parts



Coming in Q4-19

Accessories

No.	Dinex number	OE number	Type
1.	2AL002	1980467	Clamp
2.	2AL003	1895549	Gasket
3.	2AL004	1980468	Clamp
4.	2AL005	1895550	Gasket

Dinex diesel particulate filter kit

Dinex kit number: 2AI004
OE: 1927181



Dinex No: 2AL008
Type: Gasket



Dinex No: 2AL009
Type: Clamp



Dinex No: 2AL010
Type: Thin gasket

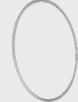

Dinex No: 2AL011
Type: Rope



Dinex No: 2AL012
Type: Knitwire

Coming in Q4-19

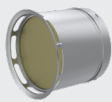

Dinex No: 2AI000
OE number: 1891485
Type: Diesel Particle Filter

System number: 121000086

Sensors

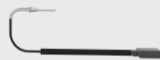

Dinex No: 22042
OE number: 1851853 - SCR
Dinex No: 22043
OE number: 1863283 - DPF
Type: Temperature Sensor



Dinex No: 22035
OE number: 1953530 / 1928760
Type: NOx Sensor

Coming in Q4-19

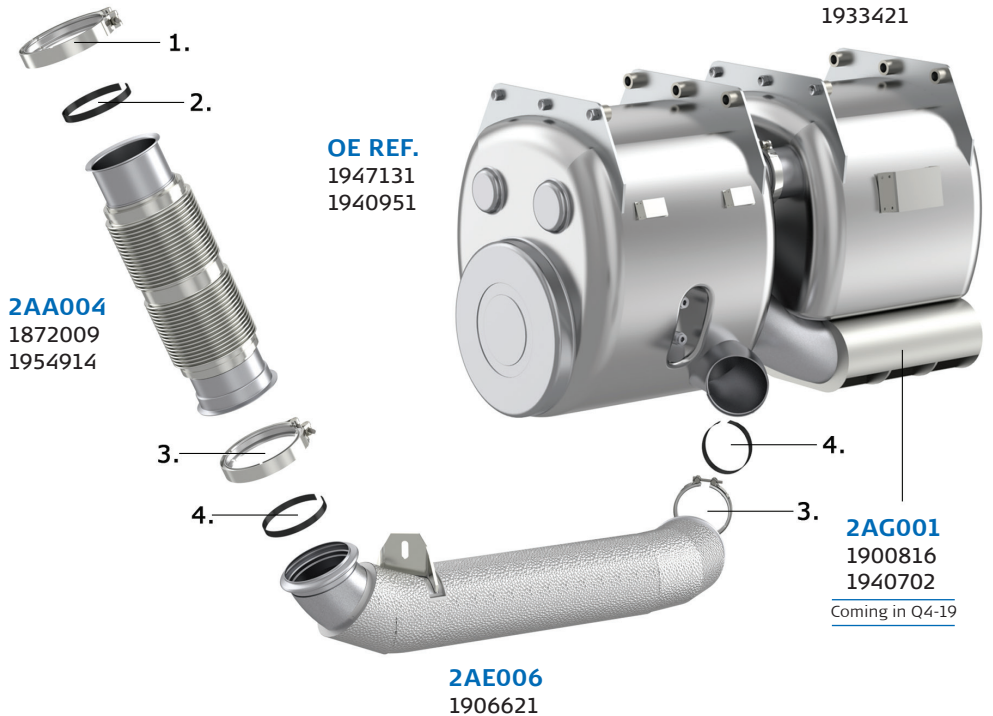

OE REF.
1947131
1940951

2AA004
1872009
1954914

OE REF.
1924181
1933421

2AG001
1900816
1940702

Coming in Q4-19

2AE006
1906621

EURO 1

1982



The Dinex Group was founded in Middelfart, Denmark

1990



Shares in French sister company ETMA France

1992



Dinex Exhaust was established in UK



Stralis

EURO 6 - Horizontal RHD / LHD

A one-box ATS system with cordierite DPF, DOC and SCR coupled with insulated front-pipe for maximum heat retention and emission reduction efficiency. DPF has easy access for replacement or maintenance. Dinex also offers wide range of exhaust pipes and other parts related to exhaust system for Iveco trucks.

Replacement parts



Dinex diesel particulate filter kit

Dinex kit number: 2KJ000
OE: 5801651134



Dinex No: 2KL014
Type: Clamp

Dinex No: 2KL016
Type: Gasket

Dinex No: 2KL015
Type: Flat Clamp

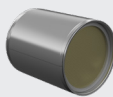

Dinex No: 2KI002
OE number: 5801651187
Type: Diesel Particle Filter

System number: 128000008



2KA000
5801292786
5801992211



OE REF.
5801429215



2KG001
503123055

Accessories

No.	Dinex number	OE number	Type
1.	29806	41201881	Clamp
2.	2KL001	41288279	Clamp
3.	2KL002	5801491218	Clamp

Coming in Q4-19

Coming in Q4-19

Manufacturers part numbers are quoted for reference only

EURO 2

1996

1998

EURO 3

2000



Dinex GmbH was established in Germany



Torben Dinesen became CEO



TGS / TGX

EURO 6 - Horizontal

A very compact and lightweight one-box ATS system. Designed for easy maintenance, this one-box solution combines ATS efficiency together with easily replaceable DPF unit. The result is smooth, prolonged operation with emission reduction that matches OE level. All parts are from stainless steel to ensure lifetime of exhaust system. Dinex also offers all exhaust pipes and other parts related to exhaust system for MAN trucks.

Replacement parts

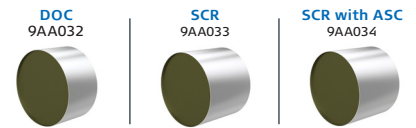

Dinex diesel particulate filter kit

Dinex kit number: 4IJ000
OE: 81.15103.6130

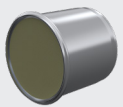

Dinex No: 4IL001
OE number: 81.15103.0107
Type: Diesel Particle Filter



Dinex No: 4IL003
OE number: 81.15901.0043
Type: Gasket



Dinex No: 4IL005
OE number: 81.15901.0044
Type: Gasket



Dinex No: 4IL004
OE number: 81.97420.0184
Type: Clamp



Dinex No: 4IL006
OE number: 81.97420.0185
Type: Clamp

System number: 147000019

Sensors

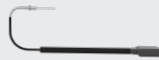

Dinex No: 47041
OE number: 51.27421.0293
51.27421.0310
Type: Temperature Sensor



Dinex No: 4IL018
OE number: 51.15408.0011
51.15408.0018
Type: NOx Sensor

Accessories

No.	Dinex number	OE number	Type
1.	4IL002	81.15901.0042	Gasket
2.	68835	06.67419.0006	Clamp

Manufacturers part numbers are quoted for reference only

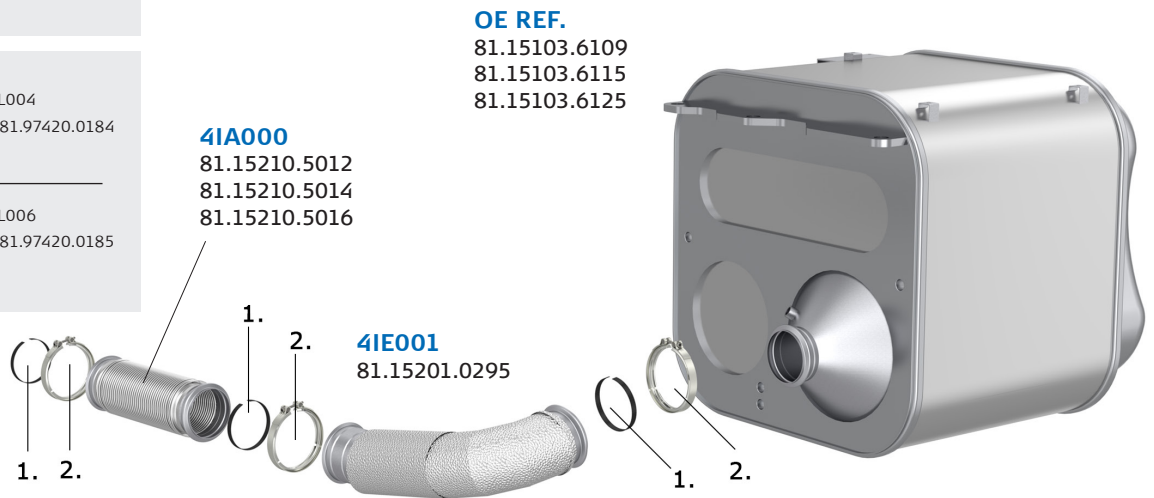

2001



Dinex Latvia and Dinex Italy were established

2002



Dinex Polska was established in Poland

2003



100% ownership of ETMA France (Dinex France)

Actros

EURO 6 - Horizontal RHD / LHD

A truly unique ATS solution comprising a replaceable, high quality silicon-carbide DPF for more soot capacity with a PGM loading on the same level as OE and cordierite DOC and SCR for the highest NOx reduction. Silicon-carbide DPF gives a more durable, effective DPF solution. Dinex also offers wide range of exhaust pipes and other parts related to exhaust systems for Mercedes trucks.

Coming in Q4-19

Replacement parts

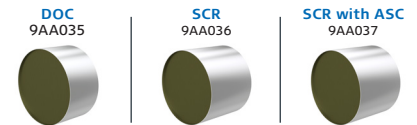

Coming in Q4-19

Accessories

No.	Dinex number	OE number	Type
1.	5AL010	003.995.7302	Clamp
2.	5AL009	000.492.1180 000.492.1480 000.492.0380	Gasket

Dinex diesel particulate filter kit

Manufacturers part numbers are quoted for reference only

- 

Dinex No: 5AI005
OE number: 001.490.5292
Type: Diesel Particle Filter
- 

Dinex No: 5AL001
OE number: 001.995.4544
Type: Clamp
- 

Dinex No: 35822
OE number: 680.995.0202
Type: Clamp
- 

Dinex No: 5AL005
OE number: 000.491.1380
Type: Gasket
- 

Dinex No: 5AL006
OE number: 000.988.3270
Type: Seal

System number: 15000032

Sensors

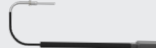
- 

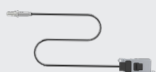
Dinex No: 51043
OE number: 010.542.0218
010.542.7118
010.542.0318
Type: Temperature Sensor
- 

Dinex No: 51034
OE number: 009.153.7128
009.153.7328
009.153.7428
Type: NOx Sensor

Coming in Q4-19

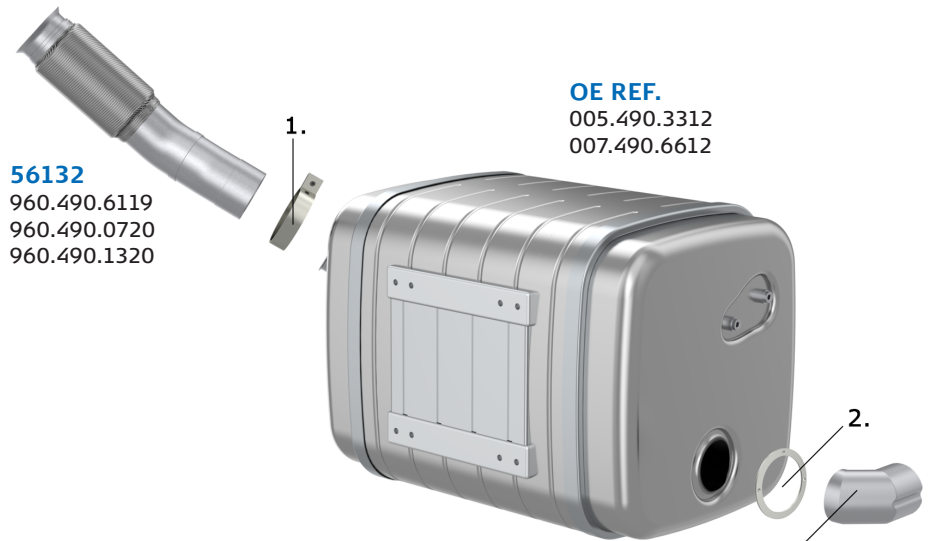

56132
960.490.6119
960.490.0720
960.490.1320

OE REF.
005.490.3312
007.490.6612

5AG009
000.492.1514
000.492.1614

Coming in Q4-19

EURO 4



Acquisition of Hildebrand GmbH in Germany
Acquisition of Commercial Exhaust in UK



Dinex Russia was established in St. Petersburg



Dinex Clamps was established in UK (Dinex Exhaust)

T model

EURO 6 - Horizontal

Very high quality ATS unit comprising replaceable cordierite DPF with PGM loading on the same level as OE to secure complete system functionality. The DOC, DPF and SCR all function together as precision tuned instruments for the highest of emission standards. Direct replacement for OE unit. Dinex also offers all exhaust pipes and other parts related to exhaust system for Renault trucks.

Dinex diesel particulate filter kit

Dinex kit number: 8AL018
OE: 21775798



Dinex No: 8AL006
OE number: 7421445539
Type: Clamp



Dinex No: 8AL005
OE number: 7421570880
Type: Gasket

x 2



Dinex No: 8AL016
OE number: 7421445536
Type: Clamp

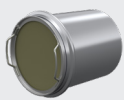

Dinex No: 8AI002
OE number: 7421716414
Type: Diesel Particle Filter

Sensors

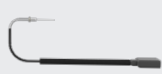

Dinex No: 81049
OE number: 21285163
7421285163
Type: Temperature Sensor

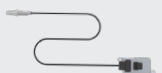

Dinex No: 81030
OE number: 7421984358
Type: NOx Sensor

Accessories

No.	Dinex number	OE number	Type
1.	8AL000	22907382 7422907382	Clamp
2.	8AL001	21758870 7421758870	Gasket
3.	8AL002	21758872 7421758872	Clamp
4.	8AL003	22907383 7422907383	Gasket
5.	80921	1629499 7401629499	Clamp

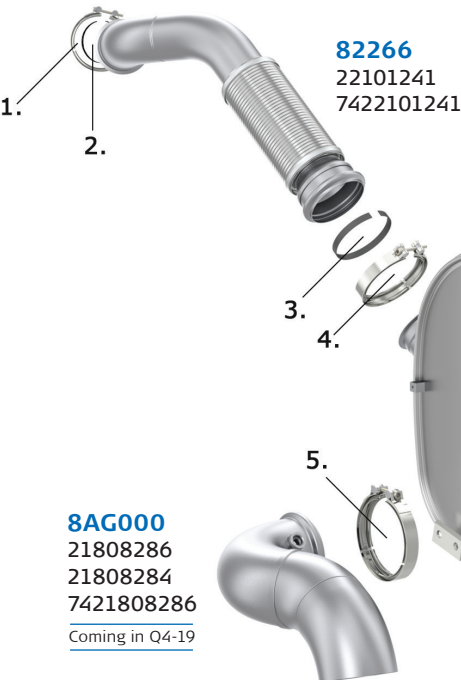

82266
22101241
7422101241

8AG000
21808286
21808284
7421808286
Coming in Q4-19

Coming in Q4-19

Replacement parts

DOC
9AA024



SCR
9AA023



SCR with ASC
9AA025

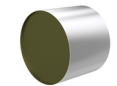

OE REF.
7421364822
21364822

System number: 164000028

EURO 5



A state-of-the-art Technology Center was established in Denmark



Dinex Turkey was established.



Dinex Balkan in Serbia and Dinex China were established

P, G, R

EURO 6 - Horizontal RHD / LHD

The only ATS unit with both – easily replaceable DPF and DOC without any cutting or welding for the most longevity. The flex-pipes are made from high quality stainless steel, wound and tested to the highest detail contributing to the benefits of replaceable substrates. Direct replacement for OE unit. Dinex also offers all exhaust pipes and other parts related to exhaust system for Scania trucks.

Dinex diesel particulate filter kit

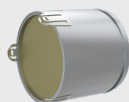

Dinex No: 6LI000
OE number: 2269640
Type: Diesel Particle Filter



Dinex No: 6LL005
OE number: 2097660
Type: Clamp



Dinex No: 6LL006
OE number: 2097659
Type: Gasket



Dinex No: 6LL008
Type: Gasket

Coming in Q4-19

Sensors

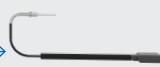

Dinex No: 67042
OE number: 2301359
Type: Temperature Sensor



Dinex No: 67031
OE number: 2294290
Dinex No: 67032
OE number: 2294291
Type: NOx Sensor

Coming in Q4-19

System number: 168000090

Accessories

No.	Dinex number	OE number	Type
1.	68835	1863831	Clamp
2.	68858	1863832	Clamp

Replacement parts

Coming in Q4-19

DOC
6LI006
OE: 2411990



SCR
9AA038



SCR with ASC
9AA039

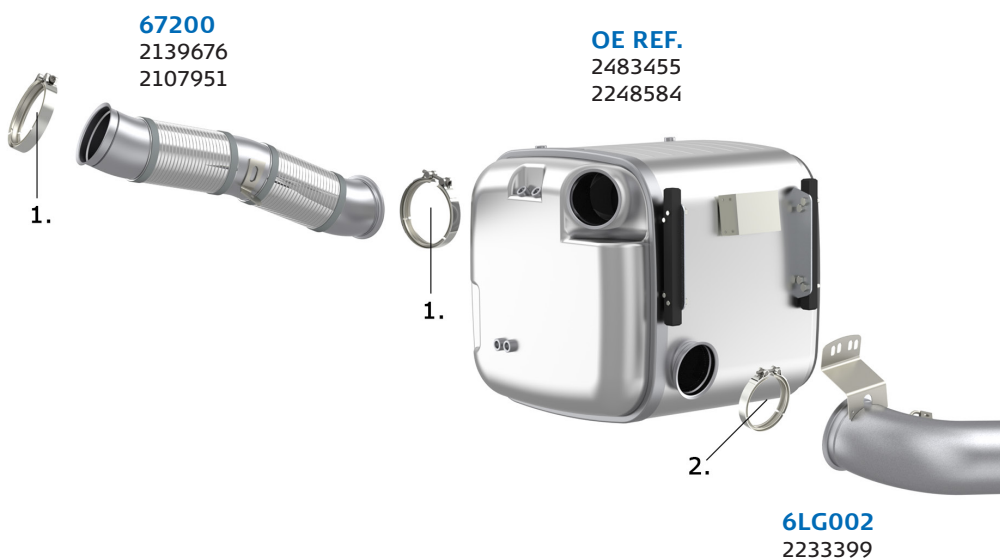

Manufacturers part numbers are quoted for reference only

EURO 6

2011



Torben Dinesen became the majority shareholder

2012



Dinex Emission was established in Dublin, USA

2013



Acquisition of Ecocat Finland (Dinex Finland)

EURO 6 - Vertical RHD / LHD

Well-designed one-box solution with the same PGM loading as OE to secure complete system functionality. This system uses cordierite DOC, DPF and SCR. DPF is easily replaceable and more affordable. Combined with the advanced DOC, SCR and high-quality insulation technologies, the emission levels are on par with that of OE. Dinex also offers all exhaust pipes and other parts related to exhaust system for Volvo trucks.

Dinex diesel particulate filter kit

Dinex kit number: 8AL019
OE: 21775801

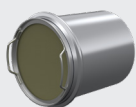

Dinex No: 8AI004
OE number: 21716417
Type: Diesel Particle Filter



Dinex No: 8AL006
OE number: 21445539
Type: Clamp



Dinex No: 8AL005
OE number: 21570880
Type: Gasket

x 2



Dinex No: 8AL016
OE number: 21445536
Type: Clamp

Sensors

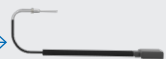

Dinex No: 81049
OE number: 21285163
7421285163
Type: Temperature Sensor



Dinex No: 81030
OE number: 22827993
Type: NOx Sensor

Accessories

No.	Dinex number	OE number	Type
1.	8AL003	22907383	Clamp
2.	8AL002	21758872	Gasket
3.	8AL000	22907382 23122882	Clamp
4.	80921	1629499 21719872	Gasket
5.	99328	20455908 8156156	Clamp
6.	99630	20743152	Clamp

Coming in Q4-19

Coming in Q4-19

Replacement parts

DOC
9AA024



SCR
9AA023



SCR with ASC
9AA025

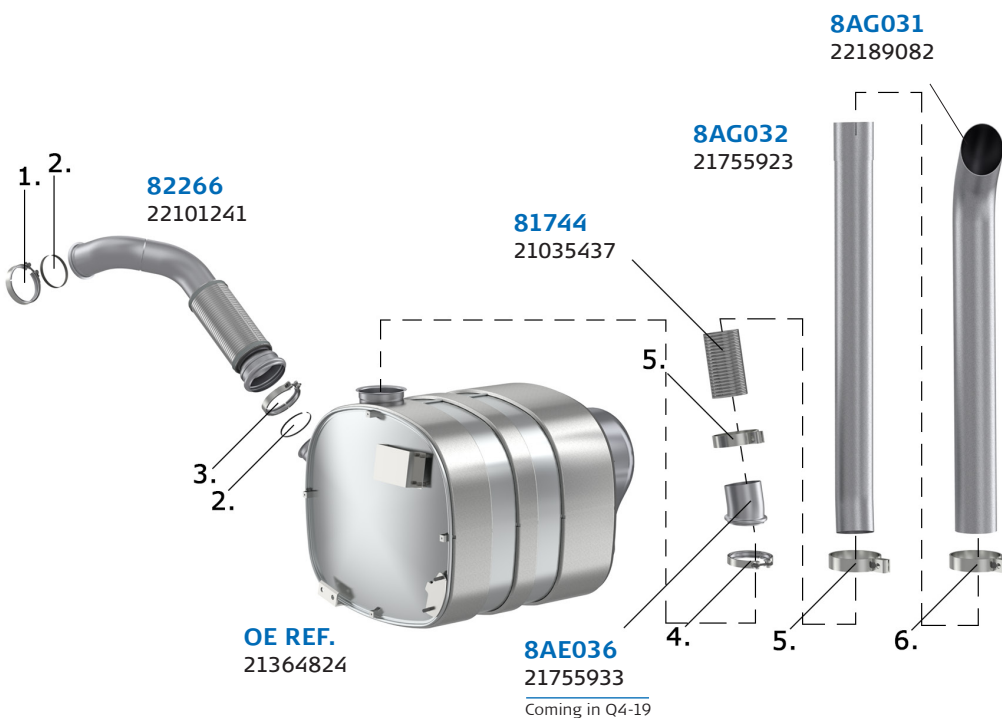

System number: 180001036

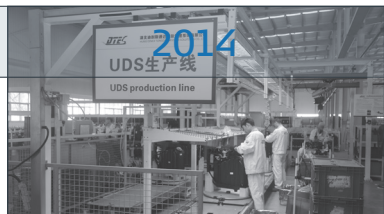

Joint Venture between China Hubei and Dinex Tongda



Partnership with 3C Group A/S

YOUR PARTNER IN EXHAUST AND EMISSION

Dinex provides system and spare part solutions throughout the exhaust system lifespan!

Supplying trucks, buses and LCVs from turbo to tailpipe.



Temperature sensors

Features:

- Directly replaceable with OE sensors
- Tested at Dinex test center
- Tested and accredited by third party
- A good choice for proper ATS functionality without compromised fuel consumption

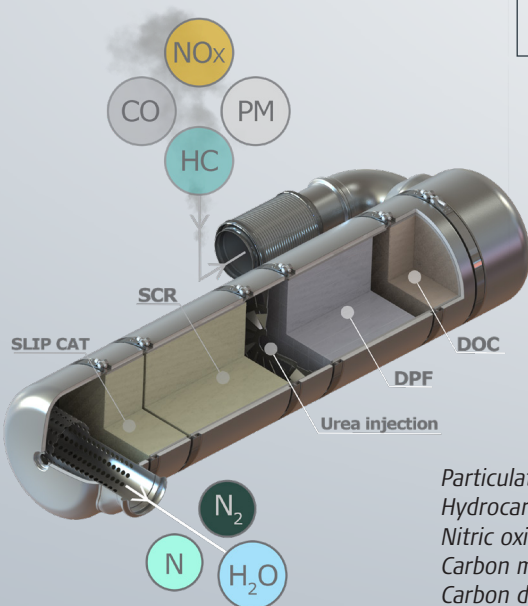
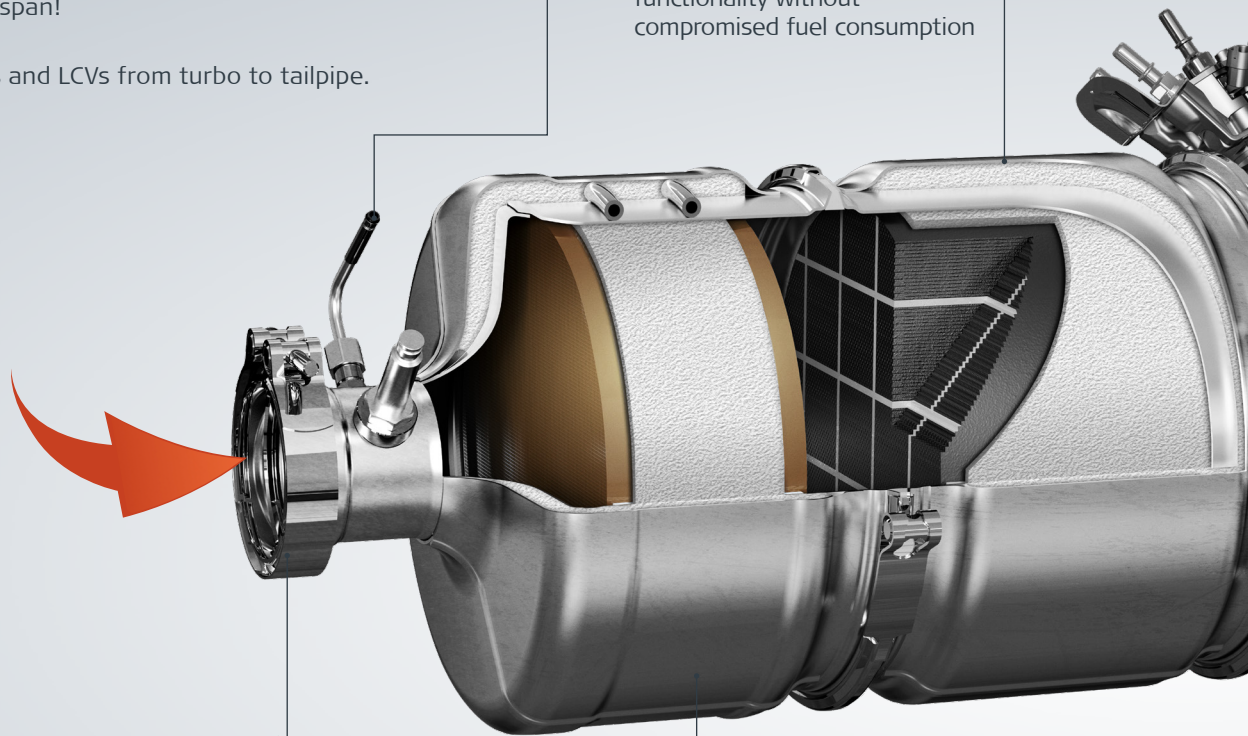

Particulate matter (PM)
Hydrocarbons (HC)
Nitric oxides (NOx)
Carbon monoxide (CO)
Carbon dioxide (CO2)

Front pipes

Material: Mild, aluminized or stainless steel

Dimensions: Ø22-152,4 mm

Features:

- Bent pipes from Ø22-152,4 mm. Avoid welding for extended lifetime.
- May be designed with bellows and D2S+ or D3S flex pipes from aluminized steel and stainless steel.
- Directly replaceable with OE parts.

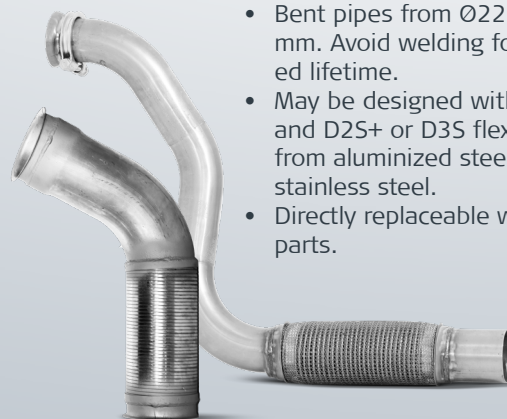



DPFs

- Material:** Cordierite or silicon carbide core
Dimensions: Ø116,5-375 mm
Features:
- In-house manufacture and coating.
 - Manufactured according to OE technology.
 - Match OE performance.

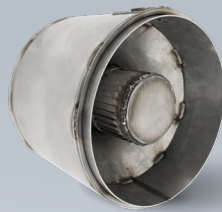

Mixers

- Material:** Stainless steel
Dimensions: Ø90-150 mm
Features:
- Mixing exhaust gas and Urea
 - Unique design for optimal exhaust gas and Urea flow.



NOx sensors

- Features:**
- Directly replaceable with OE sensors.
 - Tested at Dinex test center.
 - Tested and accredited by third party.
 - A cost effective balance between emission control and Urea consumption.

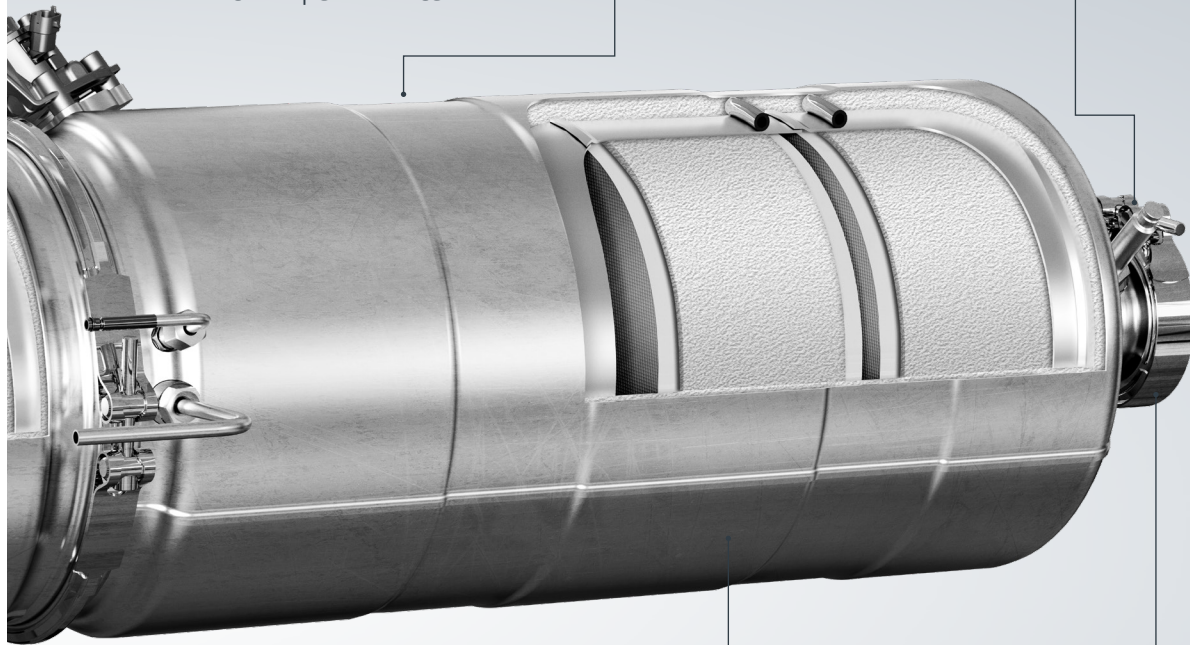

DOCs

- Material:** Metallic core
Dimensions: Ø152-350 mm
Features:
- High durability and effectiveness.
 - Reduced backpressure and fuel consumption.
 - In-house design and manufacture.
 - Match OE performance.

SCRs

- Material:** Metallic core
Dimensions: Ø152-350 mm
Features:
- High durability and effectiveness.
 - Extended lifetime and higher efficiency.
 - In-house developed technology and manufacture.
 - Match OE performance.

Tailpipes

- Material:** Mild, aluminized or stainless steel
Dimensions: Ø22-152,4 mm
Features:
- Bent pipes from Ø22-152,4 mm. Avoid welding for extended lifetime.
 - Directly replaceable with OE parts.

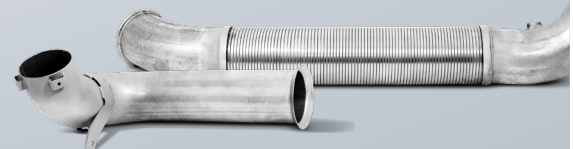

COMING SOON

Keep operating conditions under surveillance **Temperature sensors**

Maximum efficiency of the after-treatment system is ensured at high temperatures. Reliable temperature sensors are therefore vital components of the system.

Unstable sensors are costly

A malfunctioning temperature sensor is a typical root cause for partial power loss or even forcing truck engines into safe-mode, severely reducing power output. Going for less than the very best sensors is simply not worth the risk.

The reliable choice

The new temperature sensors from Dinex are designed to match the high levels of accuracy and durability demanded today. The sensors fit into all common ATS layouts in Euro IV, V and VI engines and being constructed with the very best materials.



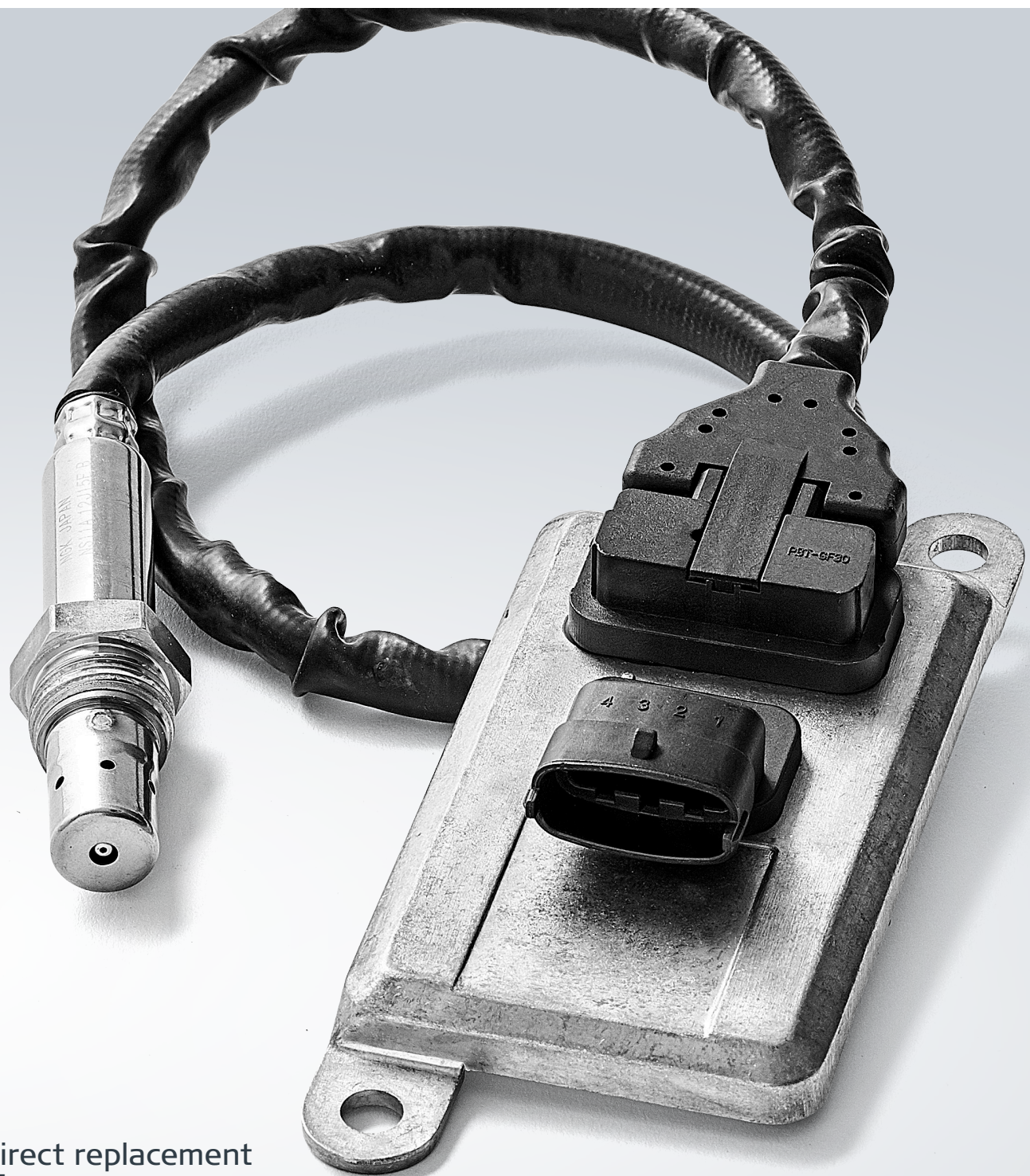

For direct replacement
of OE sensors

NOx sensors

The new NOx Sensor ensures accurate Urea dosing and can replace the OE sensor directly.

An essential part of modern trucks

A NOx (nitric oxide) sensor is typically a high-temperature device that measures the level of oxides in exhaust systems, which is strictly regulated by authorities in all parts of the world.

The measurement also helps to optimize engine operation, ensuring proper functioning of the exhaust after-treatment system.

Thoroughly tested

All NOx Sensor products match OE criteria and are calibrated and controlled at test facilities. Parts available for DAF, Iveco, MAN, Mercedes-Benz, Renault, Scania and Volvo. All products have a 1 year warranty.

The Dinex Group is a leading global manufacturer and distributor of innovative engineered exhaust and emission control products and solutions for the heavy duty and gas engine industry.

Today, the Dinex Group, headquartered in Denmark, operates through 16 companies and employs approximately 1.400 dedicated people worldwide. The Dinex Group is present in 14 different countries with production and sales facilities in Denmark, UK, Finland, Germany, Latvia, USA, Turkey, Russia and China. Additionally, the Dinex Group has sales companies in Spain, Italy, France, Germany, UK, Poland and Serbia.

Wherever you are

At Dinex **we are global in a very local way.**

Our manufacturing, sales and distribution facilities are strategically located all over the world, so that we can serve you with products and business support that match your specific needs, quickly and efficiently.

Great products, delivered!

Your ability to supply the right products when your customers need them is crucial to your business. We have a global distribution system with local warehouses and dedicated employees that are ready to help you deliver your market promise.

- The world's widest programme in exhaust and emission products, more than 15,000 spare part numbers
- Day-to-day delivery in Europe
- 24/7 order-to-invoice (TecCom)
- Our local representatives are always ready to help you solve specific needs

We speak your language

Our extensive scope of supply also includes professional support for your organisation. We know the local markets and are happy to offer technical as well as sales and marketing support, that will help improve your business.

This is what we call full scale value-added business support, delivered in your language.





Sales and Distribution

Serbia

Dinex Balkan D.O.O.
Tel +381 21 310 10 26
dinex@dinex.rs

France

Dinex France S.A.S.
Tel +33 1 69 11 88 00
dinex@dinex.fr

Germany

Dinex GmbH
Tel +49 180 225 1125
info@dinex.de

Italy

Dinex Italia S.r.l.
Tel +39 085 8028693
dinex@dinex.it

Poland

Dinex Polska Sp. z o.o.
Tel +48 58 712 66 55
dinex@dinex.pl

Spain

Dinex Ibérica
Tel +34 93 656 81 40
dinex@dinexescape.es

Production, Sales and Distribution

Denmark (Head Office)

Dinex A/S
Tel +45 63 41 25 00
dinex@dinex.dk

Latvia

Dinex Latvia SIA
Tel +371 63020200
dinex@dinex.lv

Russia

Dinex RUS LLC
Tel +78 126 104 007
dinex@dinex.net

Turkey

Dinex Egzoz ve Emisyon
Tel +90 282 736 4040
dinex@dinex.com.tr

United Kingdom

Dinex Exhausts Ltd.
Tel +44 1925 849 849
dinex@dinex.co.uk

Finland

Dinex Finland Oy
Tel +358 10 65351
info@dinex.fi

China

Dinex Emission System
Tel +86 519 8108 5931
dinex@dinex.cn

USA

Dinex Emission Inc.
Tel +1 478 272 2466
dinex@dinexemission.com

Dinex is ready to serve you



going the extra mile



Dinex.net

09-2019 / 1AA021 "All rights reserved. All illustrations are the property of Dinex and cannot be copied, duplicated or reprinted in any form without the prior written consent from Dinex."